

# FILTER / REGULATOR

## AL 981-FR

### Description

Combined filter and regulator for air preparation, with compact design for space saving. For best performance, regulated pressure should always be set by increasing the pressure up to the desired setting.

- Integral BSPP ports 1/4", 1/2", 3/4"
- High efficiency 5 micron element as standard
- Excellent water removal efficiency
- Robust but lightweight aluminum construction
- Positive bayonet latch to ensure correct and safe fitting
- Metal bowl standard.

### Versions

Type	Port size	Gauge range (bar)	Flow* dm <sup>3</sup> /s	Max. bar	Drain	Article number
FR1	1/4"	10	35	17	Manual	6821440
					Pulse	6821443
FR2	1/2"	8	64	17	Manual	6822440
					Auto	6822445
FR2	3/4"	108	108	17	Manual	6823440
					Auto	6823445

\* Flow with 10 bar inlet pressure, 6.3 bar set pressure and 1 bar pressure drop.

### Technical data

Type	AL 981-FR1	AL 981-FR2	AL 981-FR3
Operating temperature	-10°C - +65°C	-25°C - +65°C	-25°C - +65°C
Max. supply pressure	17 bar	17 bar	17 bar
Standard filtration	5 micron	5 micron	5 micron
Port size	1/4"	1/2"	3/4"
Gauge port (2 ea.)	1/8"	1/4"	1/4"
Air quality	Within ISO 8573-1: 1991 Class 3 (Particulates) Within ISO 8573-1: 2001 Class 6 (Particulates)		

### Options and spare parts

- Adjusting pressure ranges 0-2 bar / 0-4 bar / 0-8 bar / 0-16 bar (0-17 bar FR2 and FR3)
- Plastic bowl
- Assembled combinations with lubricators, shut-off valves, manifolds.

Article	Type	Article number
5µ particle filter element	AL 981-FR1	6821129
	AL 981-FR2	6822129
	AL 981-FR3	6823129
Wall mounting bracket	AL 981-FR1	6821521
	AL 981-FR2	6822521
	AL 981-FR3	6822522

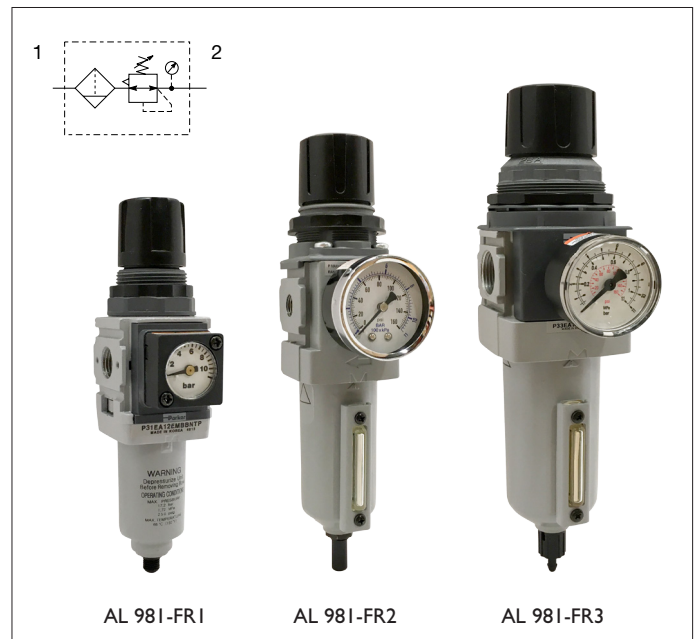

AL 981-FR1 - 1/4"

Flow chart

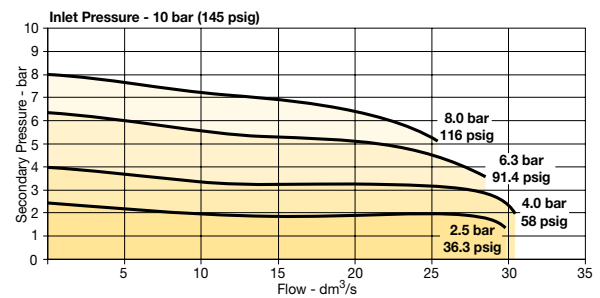

AL 981-FR2 - 1/2"

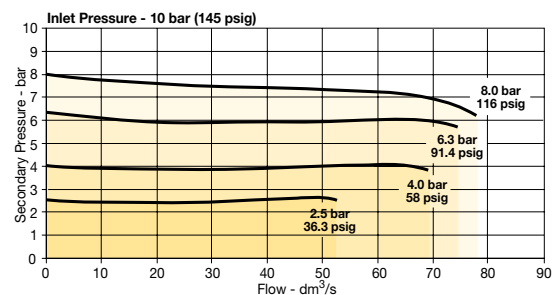

AL 981-FR3 - 3/4"

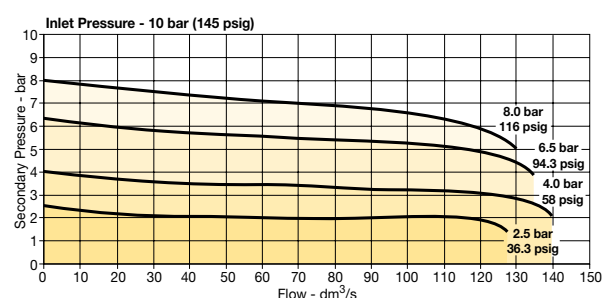

# FILTER / REGULATOR

## AL 981-FR

### Dimensions

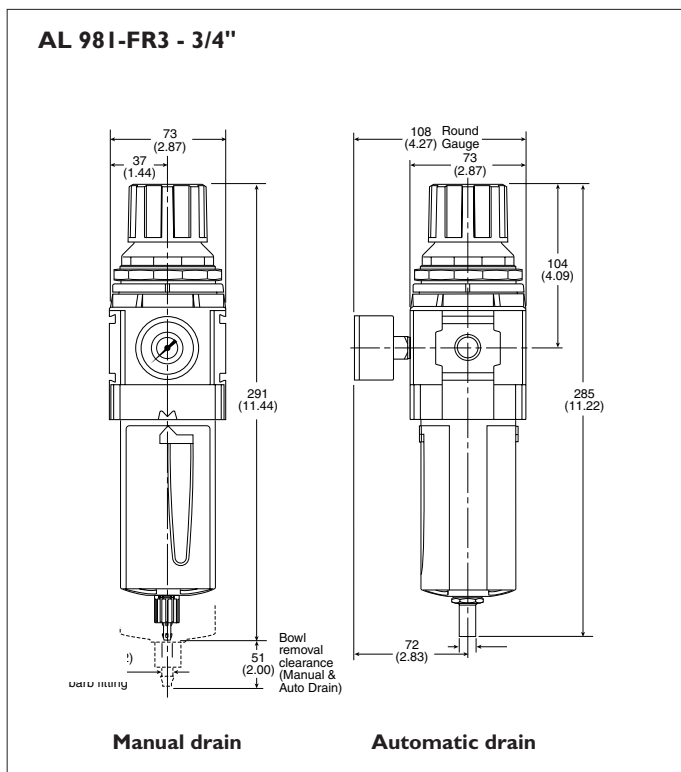
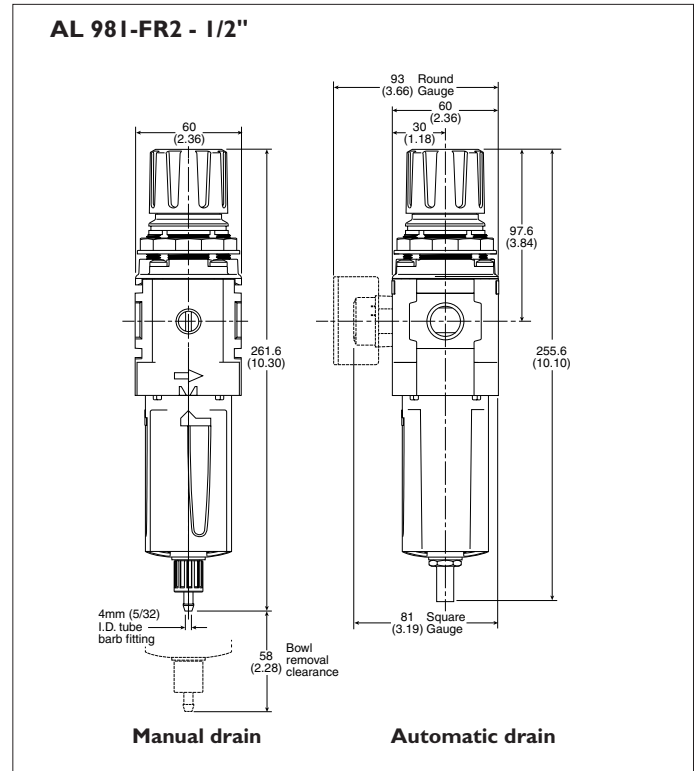
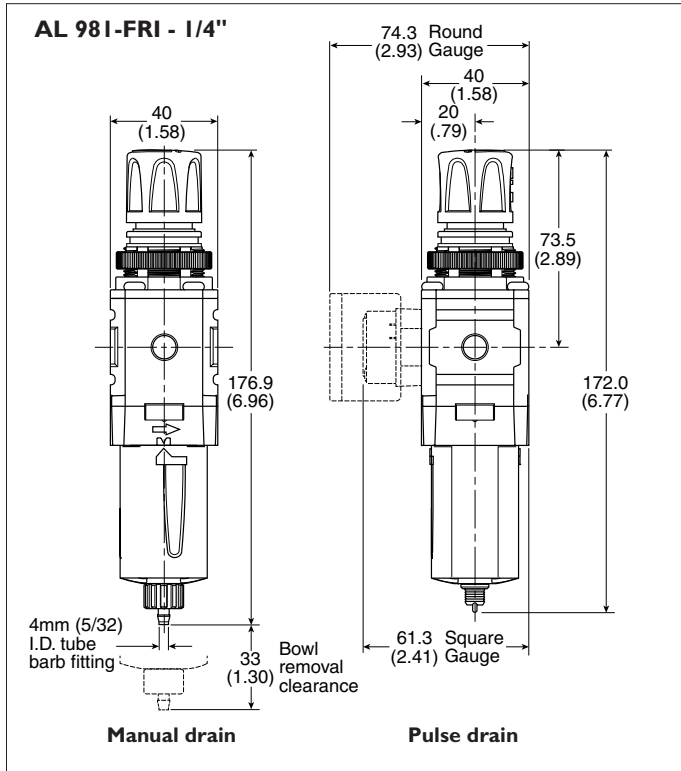

### Material specification

Part	AL 981-FR1	AL 981-FR2	AL 981-FR3
Body	Aluminium	Aluminium	Aluminium
Adjustment knob	Acetal	Acetal	Acetal
Filter element	Polyethylene	Sintered polyethylene	Sintered polyethylene
Seals	Nitrile	Nitrile	Nitrile
Springs	Steel	Steel / S.S.	Steel / S.S.
Valve assembly	Brass / Nitrile	Brass / Nitrile	Brass / Nitrile
Diaphragm assembly	Brass / Nitrile	Nitrile / Zinc	Nitrile / Zinc
Panel nut	Acetal	Acetal	Acetal
Sight gauge	-	Polycarbonate	Polycarbonate