

FRL-KOMPONENTER

AL 981 - Regulatorer

Beskrivning

Tryckregulatorer för luftbehandling. För bästa prestanda bör reglertrycket alltid sättas genom att öka upp till önskad inställning.

Processanslutning: G 1/4", 3/8", 1/2", 3/4"
Sekundärtryck bar: 0-2, 0-4, 0-8
Arbetstemperatur: -25°C - +65°C
Max. matningstryck: 20 bar

Utförande / Tekniska data

Typ	Anslutning	Flöde dm ³ /sek *
AL 981-R31	1/4"	32
AL 981-R32	1/4"	70
AL 981-R32	3/8"	78
AL 981-R32	1/2"	78
AL 981-R33	1/2"	110
AL 981-R33	3/4"	110

* Inloppstryck 10 bar, sekundärtryck 6,3 bar



Flödesdiagram

Typ 31 - 1/4"

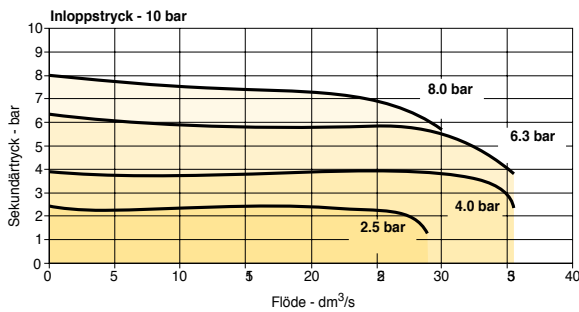

Typ 32 - 1/2"

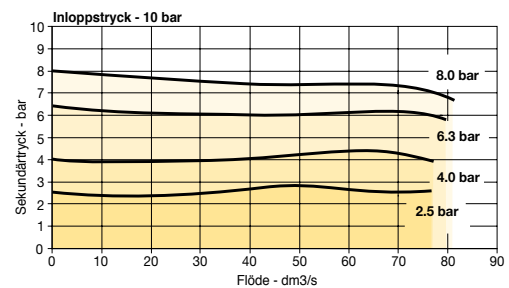

Typ 32 - 1/4"

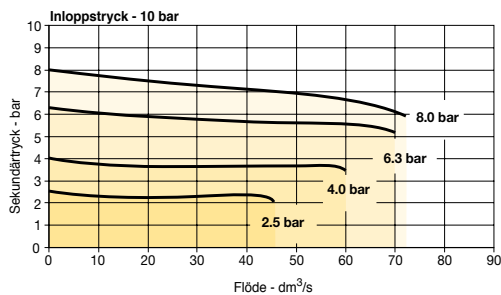

Typ 33 - 1/2"

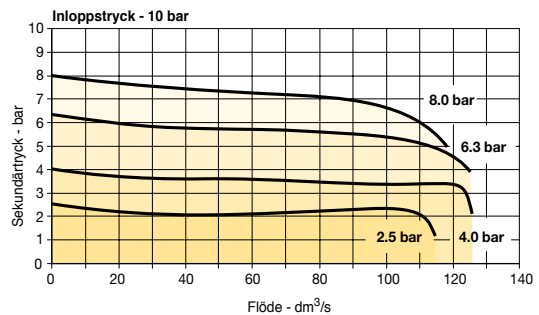

Typ 32 - 3/8"

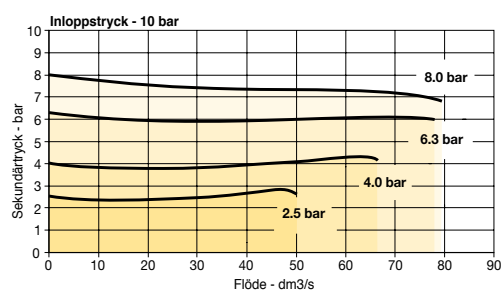

Typ 33 - 1/2"

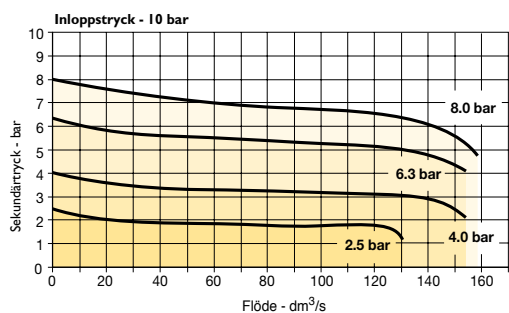

FRL-KOMPONENTER

AL 98I - Regulatorer

Måttuppgifter

Typ 31

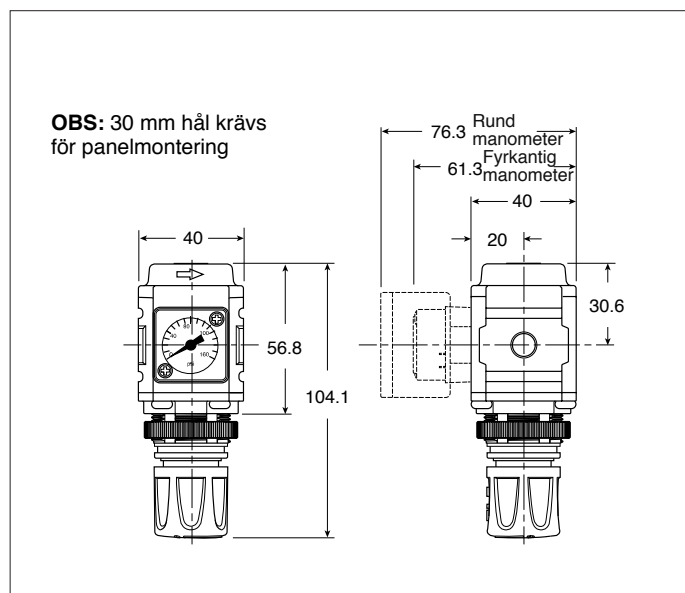

Typ 32

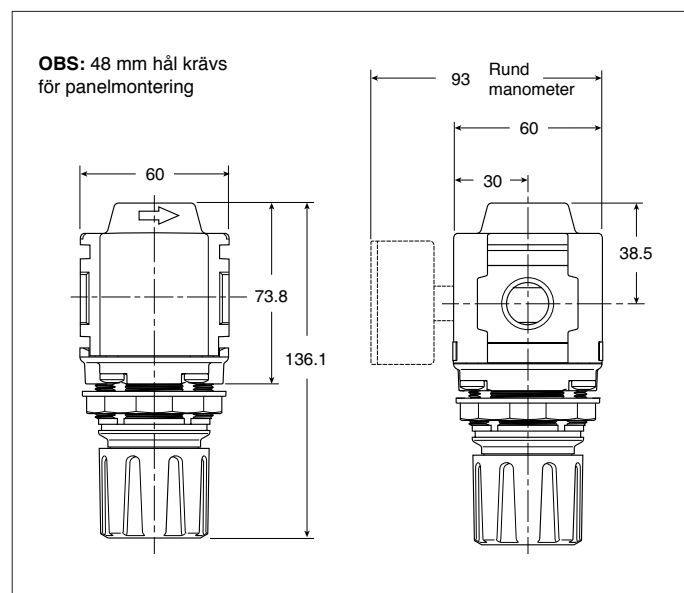

Typ 33

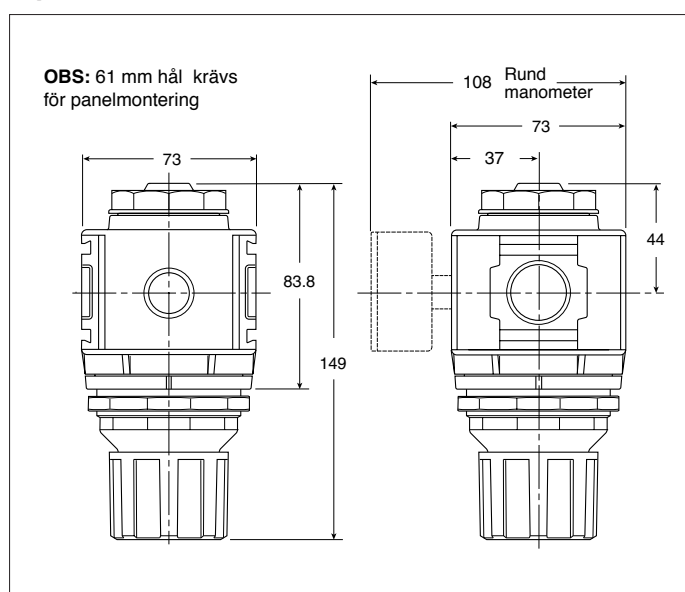

Kontakta oss för utförlig teknisk information på dessa produkter!